

Site Area 1,532 m²

revision	date	description
A	08 07 2021	Red line amended
B	30 07 2021	Bin store added as requested by LPA

The Stables Manor Farm Courtyard Southam Chichester Gloucestershire GL52 3PB Tel: 01242 898388 www.bpplanning.co.uk	15 Harrison Grove Worcester Gloucestershire W15 5LS Email: info@keystonead.co.uk Tel: 0775278244 www.keystonead.co.uk

Project	: Change of use from Cranny Annex to separate dwelling
Site Address:	Croft Amber, Green Street, Brockworth, Gloucester, Gloucestershire, GL3 4RT
First issue date:	05 07 2021
Scale:	1:250 (A4)
Title: Location Plan	drawing no: K2105-01
	revision B

This drawing is the copyright of KAD & BPA and must not be copied or reproduced without our consent. DO NOT SCALE this drawing, use figured dimensions only. The contractor is to check all dimensions on site, report all discrepancies to the architect.

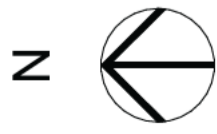

215500

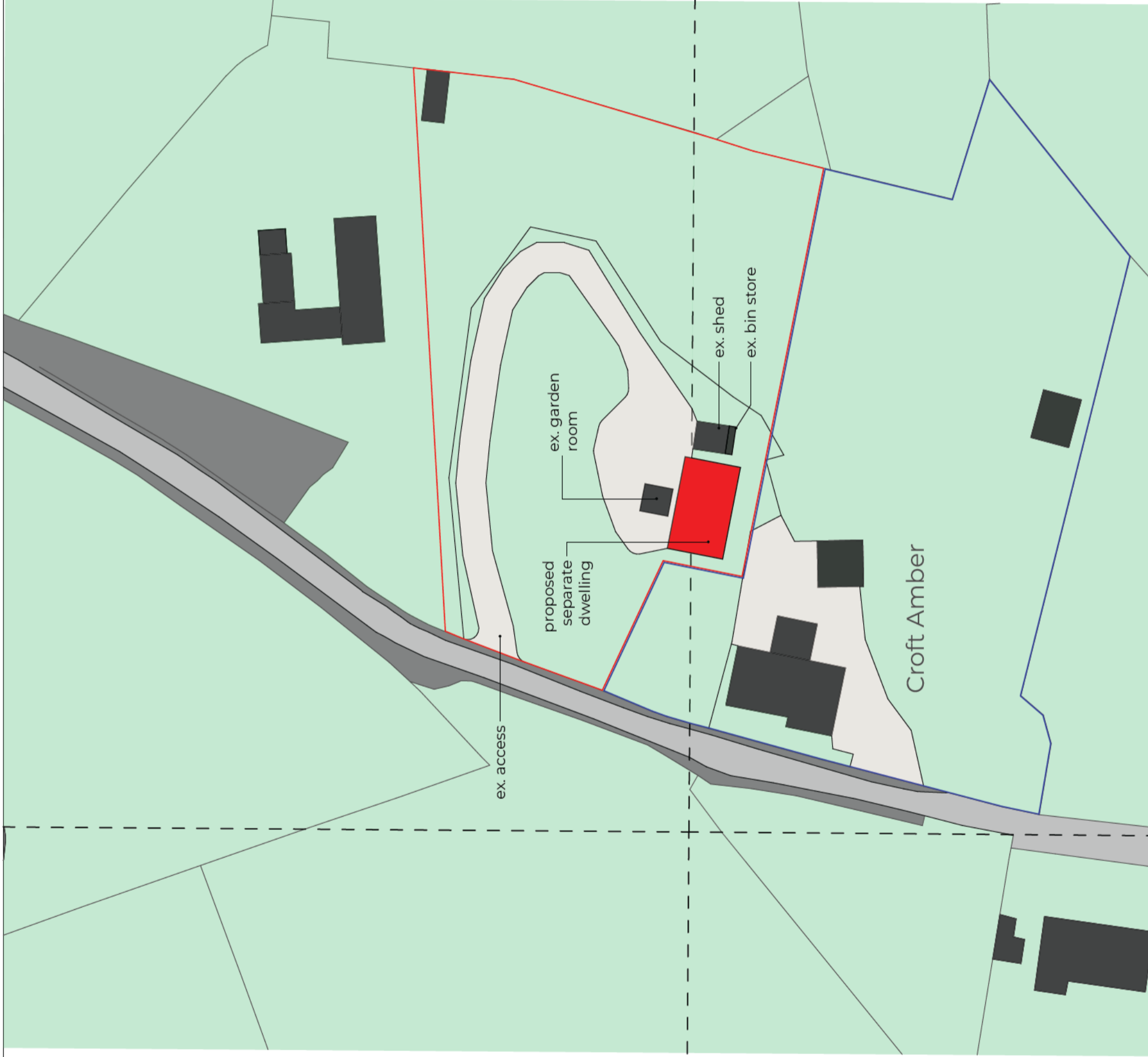

revision	date	revisions description
A	08 07 2021	Red line amended
B	30 07 2021	Bin store added as requested by LPA

BP brodie
planning
associates

KEYSTONE
ARCHITECTURE
& DESIGN

The Shales (Moor Farm, Courtwood, Easton, Charnham) Gloucestershire GL3 3PB
Tel: 01242 896169 | www.brodeplanning.co.uk

15 Fairfield Close, Worcester, Gloucestershire | WR5 1SS
Tel: 01292 279744 | www.keystonead.co.uk

Project : Change of use from Granny Annex to separate dwelling

Site Address: Croft Amber, Green Street, Brockworth, Gloucestershire GL3 4RT

First issue date: 05 07 2021 Scale: 1:1250 [A4]

Title: Location Plan drawing no: K2105-01

Revision B

This drawing is the copyright of KAD & BPA and must not be copied or reproduced without our consent. DO NOT SCALE this drawing, use figured dimensions only. The contractor is to check all dimensions on site, report all discrepancies to the architect.

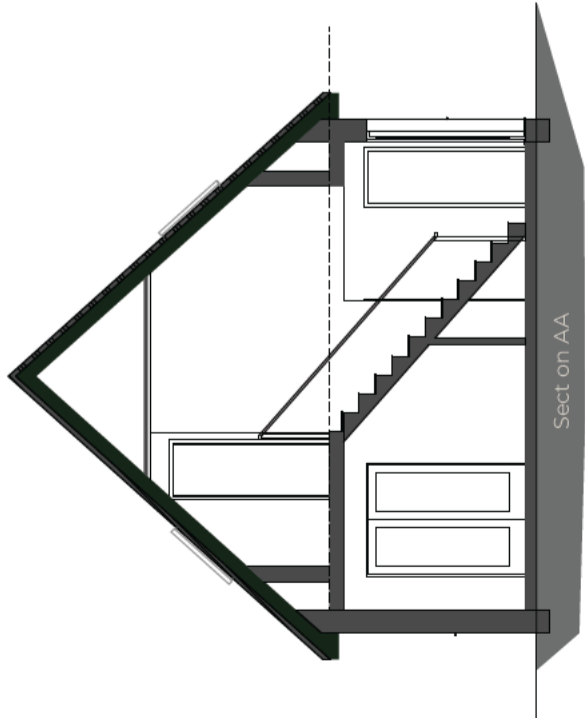
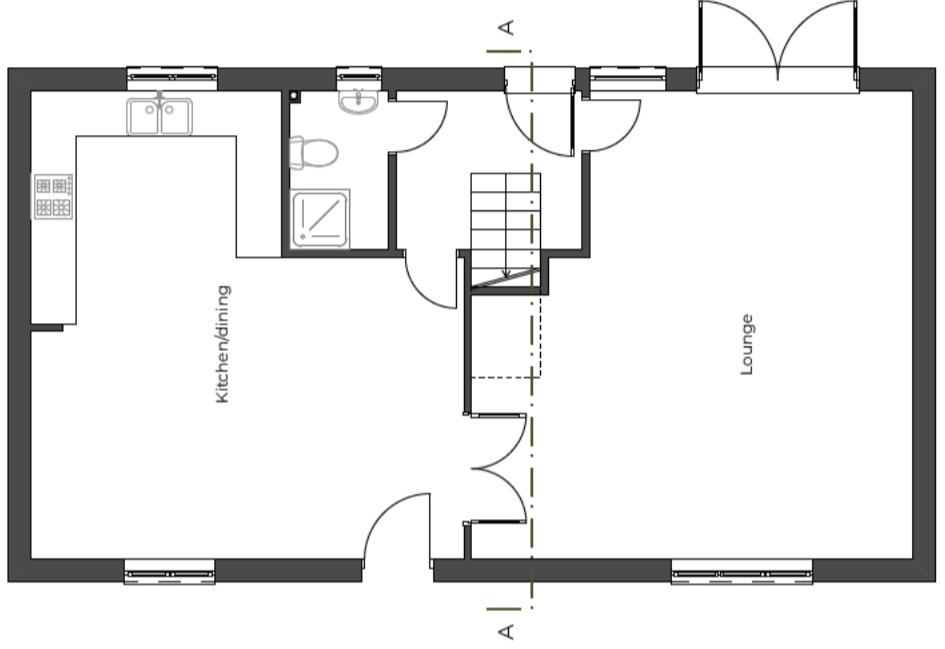
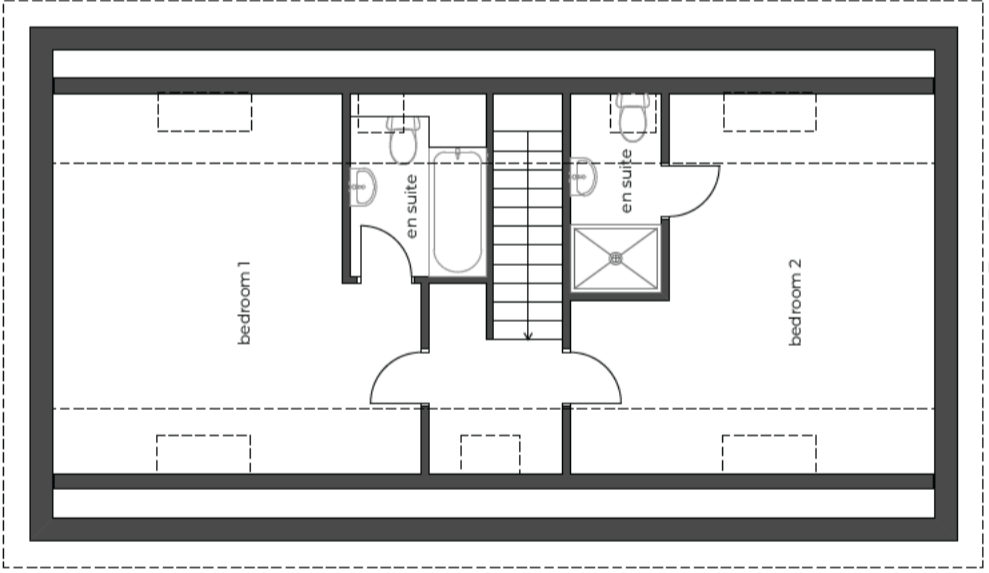
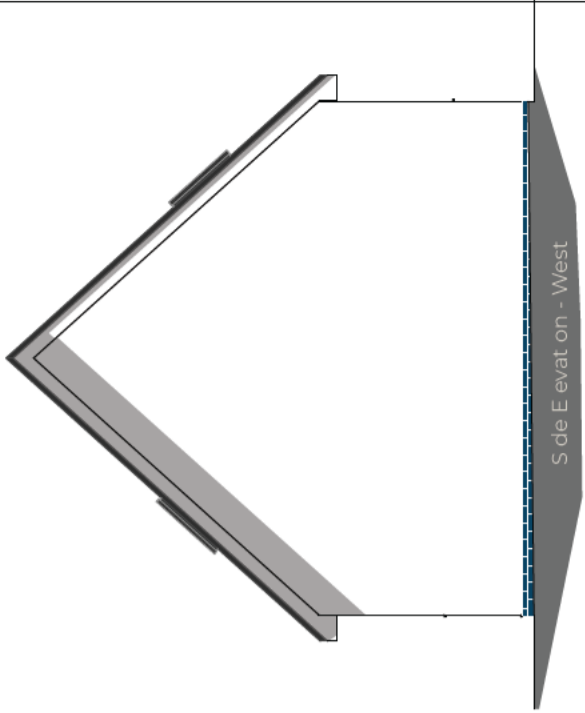
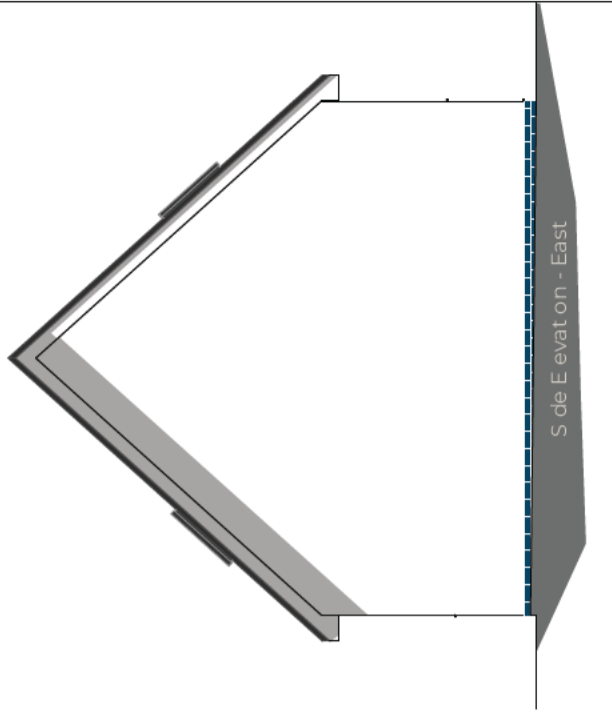
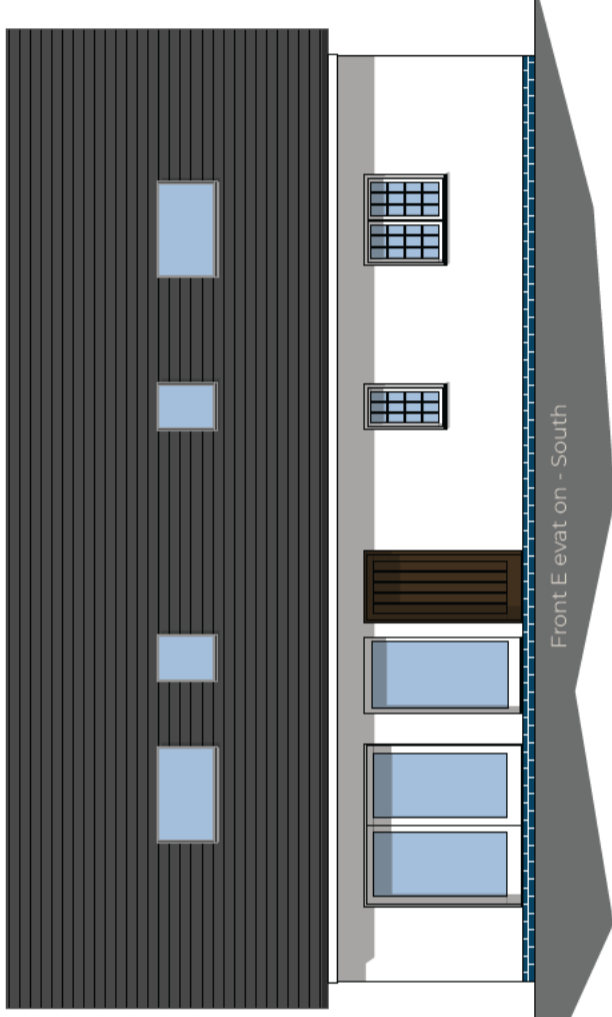
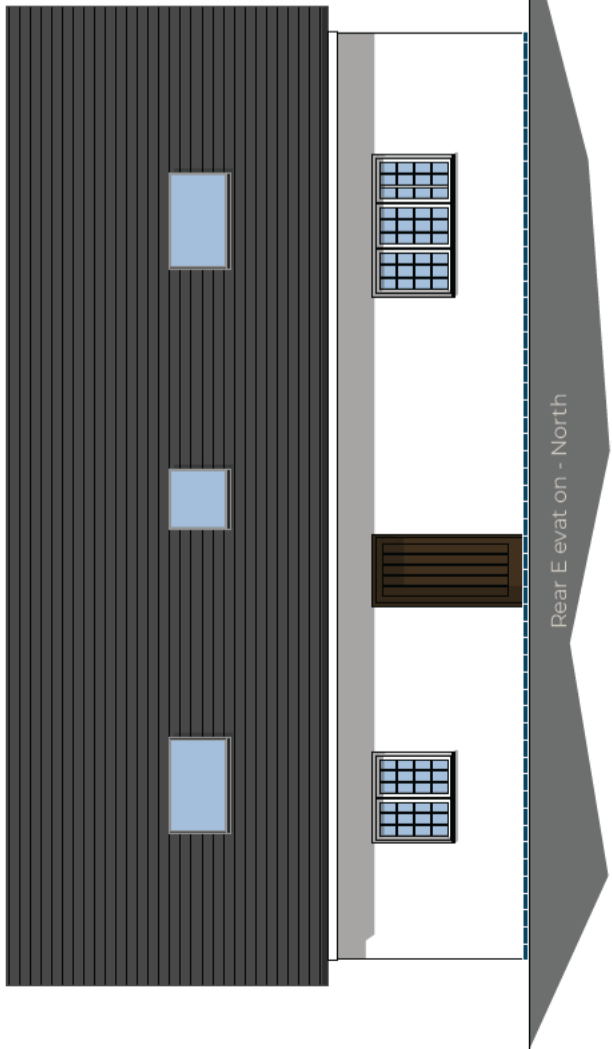

revision	date	description

brodie planning associates

The Studio | Manor Park, Coventry | CV3 3JG
 Chesham | Gloucestershire | GL3 3JG
 Tel: 01242 818058 | www.brodieplanning.co.uk

15 Fairfield Grove | Worcester | Worcestershire | WR5 1SS
 Tel: 01273 279744 | www.keystonead.co.uk

Project : Change of use from Granny Annex to separate dwelling
 Site Address: Croft Amber, Green Street, Brockworth, Gloucester, Gloucestershire GL3 4RT
 First Issue date: 05/07/2021
 Scale: 1:100 [A3]
 Title: Existing Survey
 drawing no: K2105-03
 Revision

This drawing is the copyright of KAD & BPA and must not be copied or reproduced without our consent.
 DO NOT SCALE this drawing, use figured dimensions only.
 The contractor is to check all dimensions on site, report all discrepancies to the architect.

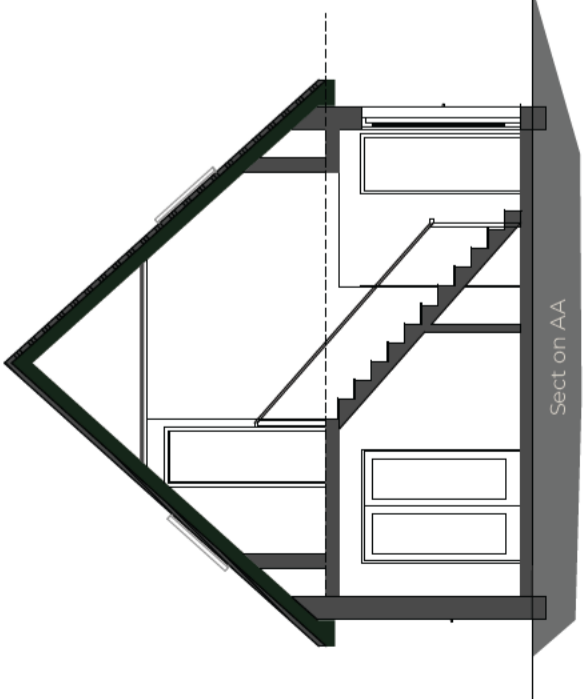
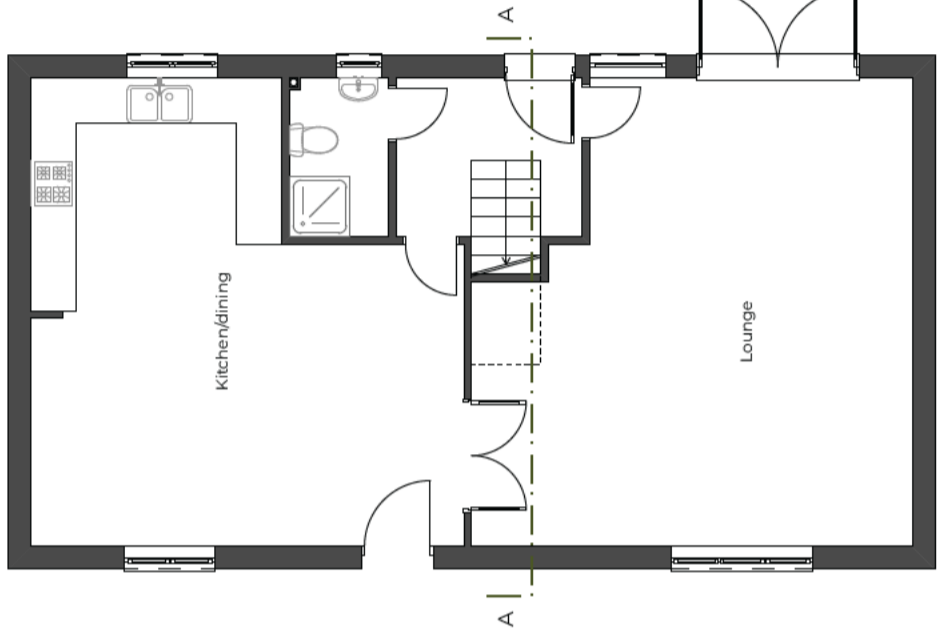
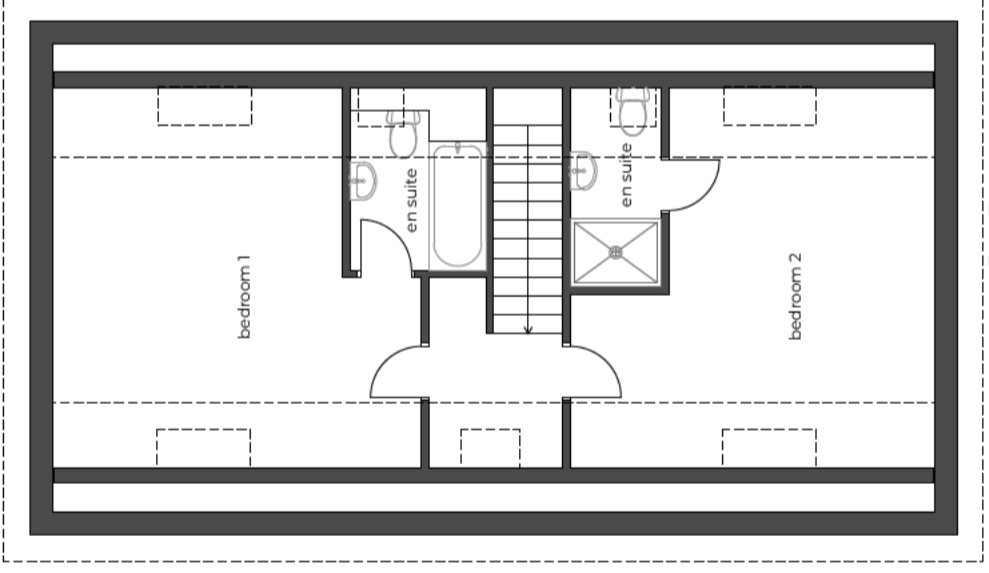
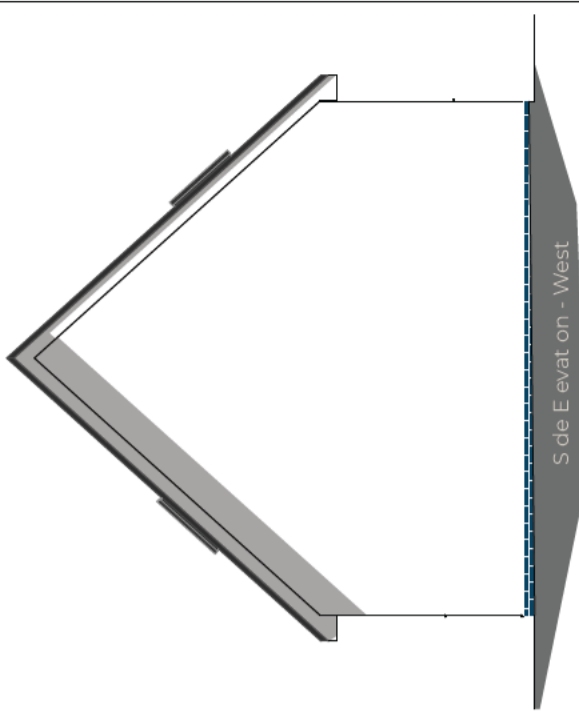
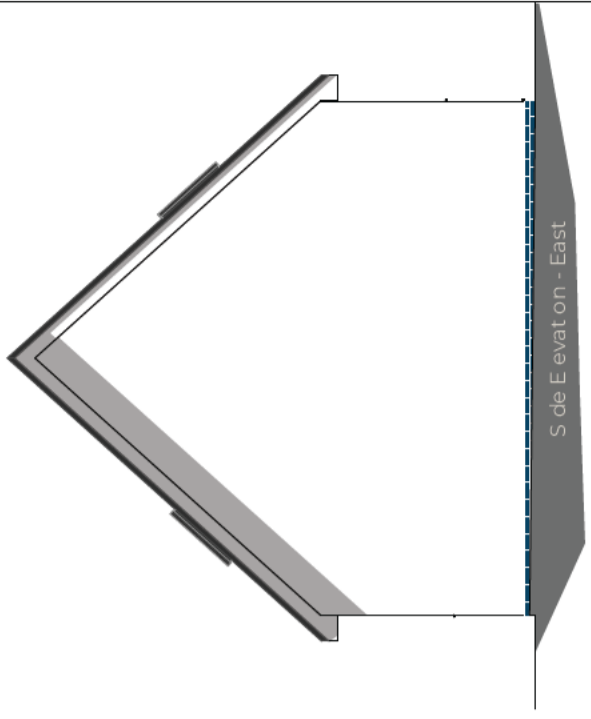
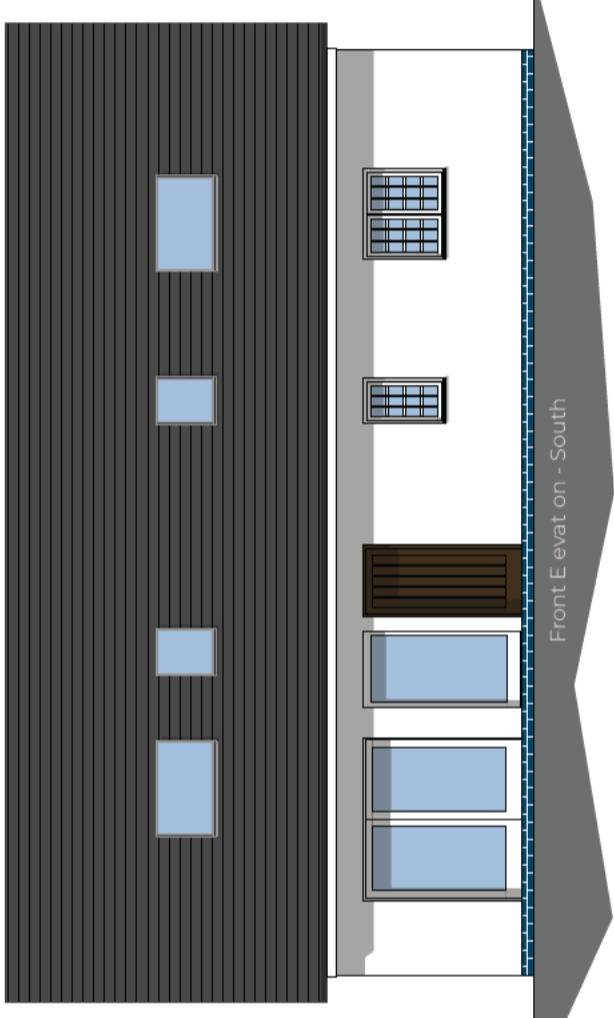
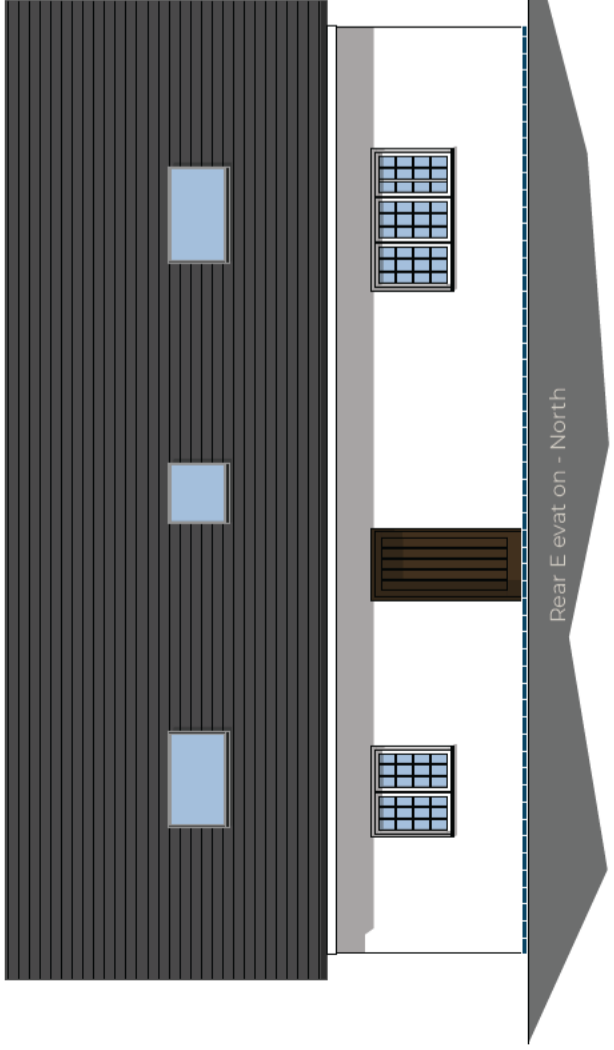

revision	date	description

<p>The Studio, Manor Park, Coombe Wood, Southam, Warwickshire, CV34 3JG Tel: 01243 818058 www.brodieplanning.co.uk</p>		
<p>15 Fairfield Grove, Worcester, Worcestershire, WR11 3SS Tel: 01273 297914 www.keystonead.co.uk</p>		
<p>Project : Change of use from Granny Annex to separate dwelling</p>		
<p>Site Address: Croft, Amber, Green Street, Brockworth, Gloucester, Gloucestershire GL3 4RT</p>		
<p>First Issue date: 05/07/2021</p>		<p>Scale: 1:100 (A3)</p>
<p>Title: Proposed Plans</p>		<p>drawing no: K2105-04</p>
<p>This drawing is the copyright of KAD & BPA and must not be copied or reproduced without our consent. DO NOT SCALE this drawing, use figured dimensions only. The contractor is to check all dimensions on site, report all discrepancies to the architect.</p>		